

cod.	Ø	pz/pcs	tub.	cardine	A	B	C	ØD	ØE	L	CodTek
861G.35/30	30	10	35	M18	35x35	35	9	Ø29	Ø28	53	ACA086105GR
861G.40/35	35	10	40	M22	40x40	40	9	Ø34	Ø33	58	ACA086106GR
861G.50/40	40	6	50	M27	50x50	45	10	Ø39	Ø43	65	ACA086107GR



Swing gates accessories



Steel components



- Components to weld
- The weld must be adequately sized to support the applied forces and with suitable electrode material.
- Adequately strengthen the areas anchoring the door and/or structure / frame.



Lubricate all parts in contact with grease (every 6 months) .
In case of anomalies, prevent the usage of the hinge and the installed product must be checked by professional personnel.



Responsibly dispose of the product and of its packaging respecting the local legislations of the Country of installation.

The company reserves the right to make technical as well as aesthetic changes without previous notice.
All responsibility due to an inappropriate use of the product is declined.

All drawings, photos, trademarks, logos, are of exclusive Combi Arialdo's property. All uses not expressly authorized by the company will be prosecuted.

1

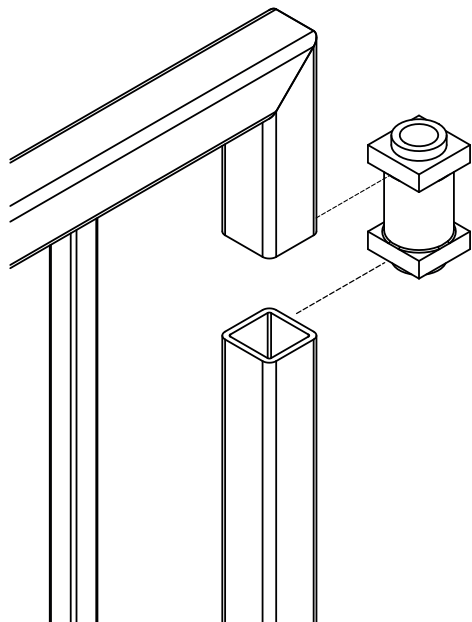

2

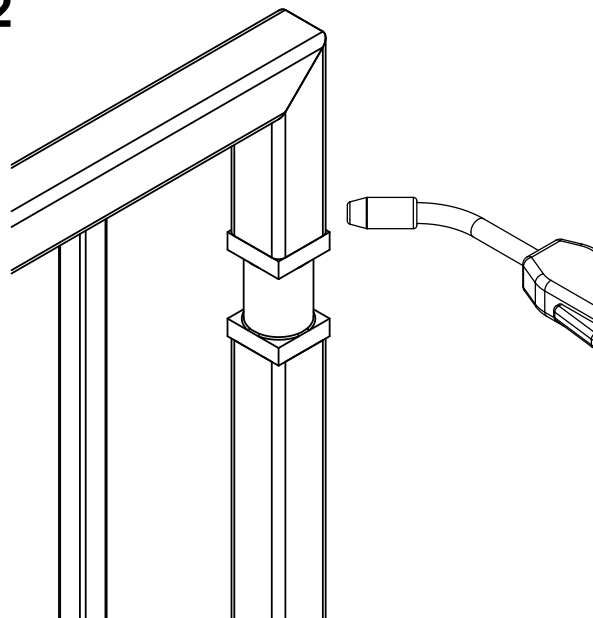

3

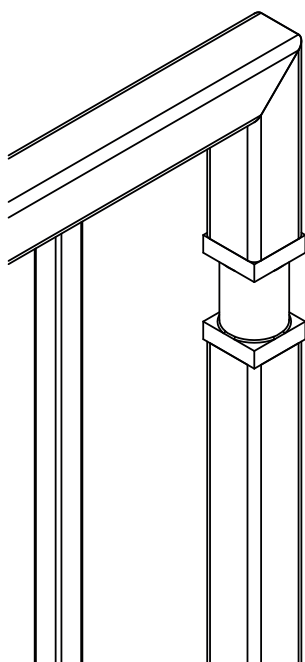

ART. 861 T

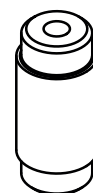

ART. 861 P

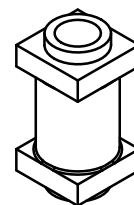

ART. 861 G

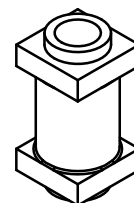

ART. 861 X

