

cod.	mm.	pz/pcs	olive	M	A	B	C	CodTek
462IX.P	PICCOLA	2	Ø30x40	M14	43-86	93-156	149-197	AAC046201IX
462IX.M	MEDIA	2	Ø40x45	M16	47-90	89-152	149-197	AAC046202IX



Sliding gates accessories



Stainless steel/nylon components



- Components to weld and to fix.
- The weld must be adequately sized to support the applied forces and with suitable electrode material.
- Adequately strengthen the areas anchoring the door and/or structure / frame.



Check the product every 6/12 months.
In case of anomalies, prevent the usage of the hinge and the installed product must be checked by professional personnel.



Responsibly dispose of the product and of its packaging respecting the local legislations of the Country of installation.

The company reserves the right to make technical as well as aesthetic changes without previous notice.

All responsibility due to an inappropriate use of the product is declined.

All drawings, photos, trademarks, logos, are of exclusive Combi Arialdo's property. All uses not expressly authorized by the company will be prosecuted.

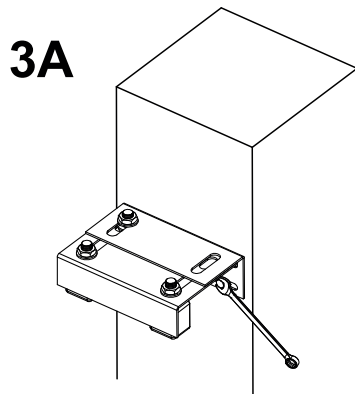
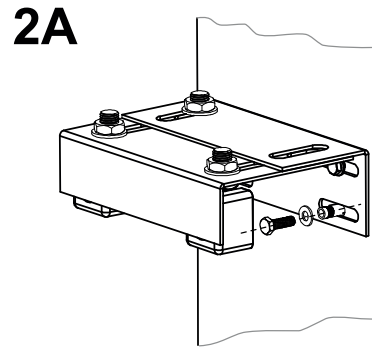
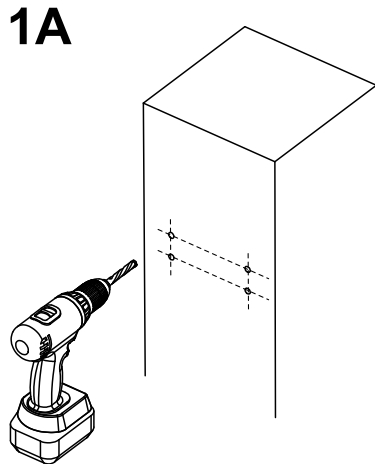

A FISSARE - TO FIX

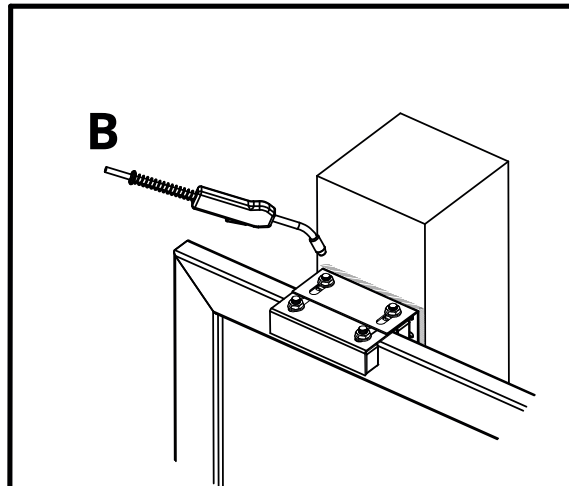

A SILDARE - TO WELD

