

cod.	mm.	pz/pcs	CodTek
456	UNICA	6	AAC045601ZB



Sliding gates accessories



Galvanized steel/nylon components



- Components to weld and to fix.
- The weld must be adequately sized to support the applied forces and with suitable electrode material.
- Adequately strengthen the areas anchoring the door and/or structure / frame.



Check the product every 6/12 months.
In case of anomalies, prevent the usage of the hinge and the installed product must be checked by professional personnel.



Responsibly dispose of the product and of its packaging respecting the local legislations of the Country of installation.

The company reserves the right to make technical as well as aesthetic changes without previous notice.

All responsibility due to an inappropriate use of the product is declined.

All drawings, photos, trademarks, logos, are of exclusive Combi Arialdo's property. All uses not expressly authorized by the company will be prosecuted.

A FISSARE - TO FIX

1A

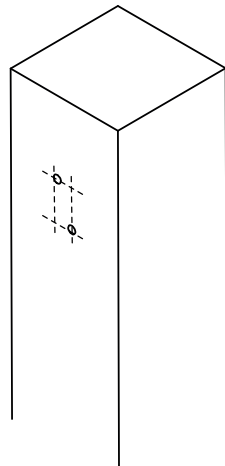
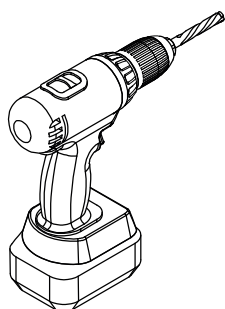

B

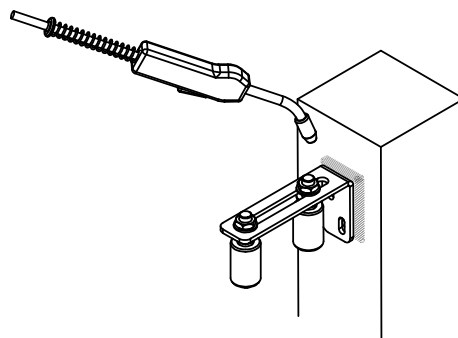

A SILDARE - TO WELD

2A

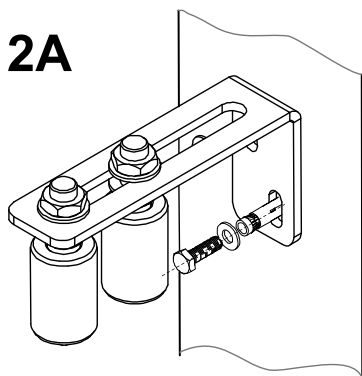

3A

